

Lecture 33

INTRODUCTION TO PNEUMATICS

Learning Objectives

Upon completion of this chapter, Student should be able to

- ✚ Explain the meaning of Pneumatics
- ✚ Describe the various properties desired of a air medium in pneumatic system
- ✚ Explain the advantages and disadvantages of compressed air
- ✚ Identify and appreciate the application of pneumatic systems in various Industries
- ✚ Describe the various gas laws
- ✚ List the basic components required for a pneumatic systems
- ✚ Describe the various power transmission systems
- ✚ Compare hydraulic, pneumatic and mechanical systems

1.1 PNEUMATICS AND ITS MEANING.

The English word pneumatic and its associate noun pneumatics are derived from the Greek “**pneuma**” meaning breath or air. Originally coined to give a name to the science of the motions and properties of air. Compressed air is a vital utility- just like water, gas and electricity used in countless ways to benefit everyday life. Pneumatics is application of compressed air (pressurized air) to power machine or control or regulate machines. Simply put, Pneumatics may be defined as branch of engineering science which deals with the study of the behavior and application of compressed air. Pneumatics can also be defined as the branch of fluid power technology that deals with generation, transmission and control of power using pressurized air. Gas in a pneumatic system behaves like a spring since it is compressible.

Any gas can be used in pneumatic system but air is the most usual, for obvious reasons. Exceptions are most likely to occur on aircraft and space vehicles where an inert gas such as nitrogen is preferred or the gas is one which is generated on board. Pure nitrogen may be used if there is a danger of combustion in a work environment. In Pneumatic control, compressed air is used as the working medium, normally at a pressure from 6 bar to 8 bar. Using Pneumatic

Control, maximum force up to 50 kN can be developed. Actuation of the controls can be manual, Pneumatic or Electrical actuation. Signal medium such as compressed air at pressure of 1-2 bar can be used [Pilot operated Pneumatics] or Electrical signals [D.C or A.C source- 24V – 230V] can be used [Electro pneumatics]

1.2 CHOICE OF WORKING MEDIUM AND SYSTEM.

The choice of medium depends on the application. Some of the general, broad rules followed in the selection of a working medium are listed below.

- When the system requirement is high speed, medium pressure (usually 6 to 8 bar) and less accuracy of position, then pneumatic system is preferred.
- If the system requirement is high pressure and high precision, a fluid system with oil is good.
- When the power requirement is high like in forging presses, sheet metal press, it is impossible to use air system. Oil hydraulics is the only choice
- Air is used where quick response of actuator is required.
- If temperate variation range in the system is large, then use of air system may run into condensation problems and oil is preferred.
- If the application requires only a medium pressure and high positional accuracy is required then hydro –pneumatic system is preferred
- Air is non-explosive, it is preferred where fire/electric hazard are expected. Oil systems are more prone to fire and electrical hazards and are not recommended in such applications.
- Because air contains oxygen (about 20%) and is not sufficient alone to provide adequate lubrication of moving parts and seals, oil is usually introduced into the air stream near the actuator to provide this lubrication preventing excessive wear and oxidation.

In a practical sense, compressed air is a medium that carries potential energy. However it can be expensive to produce, and from a simple energy efficiency point of view compressed air may not appear advantageous at first. Considering that it takes about 6 kW of electrical energy to generate

0.75 kW output on an air motor, compressed air has an efficiency rating of only 12%. In spite of that compressed air is used due to its other advantages.

Table 1.1: The advantages and disadvantages of compressed air.

Advantages of compressed air	Disadvantages of compressed air
Air is available in unlimited quantities	Compressive air is relatively expensive means of conveying energy The higher costs are, however. Largely compensated by the cheaper elements. Simpler and more compact equipment
Compressed air is easily conveyed in pipelines even over longer distances	
Compressed air can be stored	Compressed air requires good conditioning. No dirt or moisture residues may be contained in it. Dirt and dust leads to wear on tools and equipment
Compressed air need not be returned. It can be vented to atmosphere after it has performed work	It is not possible to achieve uniform and constant piston speeds(air is compressible)
Compressed air is insensitive to temperature fluctuation. This ensures reliable operation even in extreme temperature conditions	Compressed air is economical only up to certain force expenditure. Owing to the commonly used pressure of 7 bar and limit is about 20 to 50 kN, depending on the travel and the speed. If the force which is required exceeds this level, hydraulics is preferred
Compressed air is clean. This is especially important in food, pharmaceutical, textile, beverage industries	The exhaust is loud. As the result of intensive development work on materials for silencing purposes, this problems has however now largely been solved
Operating elements for compressed air operation are of simple and inexpensive construction.	The oil mist mixed with the air for lubricating the equipment escapes with the exhaust to atmosphere.
Compressed air is fast. Thus, high operational speed can be attained.	Air due to its low conductivity , cannot dissipate heat as much as hydraulic fluid
Speeds and forces of the pneumatics elements can be infinitely adjusted	Air cannot seal the fine gaps between the moving parts unlike hydraulic system
Tools and operating elements are overload proof. Straight line movement can be produced directly	Air is not a good lubricating medium unlike hydraulic fluid.

Differences between hydraulic and pneumatic systems.

One of the main differences between the two systems is that in pneumatics, air is compressible. In hydraulics, liquids are not. Other two distinct differences are given below.

Pneumatic Systems

These systems have two main features:

- Pneumatic systems use compressed gas such as air or nitrogen to perform work processes.
- Pneumatic systems are open systems, exhausting the compressed air to atmosphere after use.

Hydraulic Systems

These systems also have two main features:

- a) Hydraulic systems use liquids such as oil and water to perform work processes.
- b) Hydraulic systems are closed systems, recirculating the oil or water after use.

1.3 APPLICATIONS OF PNEUMATICS

Pneumatic systems are used in many applications. New uses for pneumatics are constantly being discovered. In construction, it is indispensable source of power for such tools as air drills, hammers, wrenches, and even air cushion supported structures, not to mention the many vehicles using air suspension, braking and pneumatic tires.

In manufacturing, air is used to power high speed clamping, drilling, grinding, and assembly using pneumatic wrenches and riveting machines. Plant air is also used to power hoists and cushion support to transport loads through the plant.

Many recent advances in air – cushion support are used in the military and commercial marine transport industry.

Some of the Industrial applications of pneumatics are listed in the [Table 1.2](#)

Table 1.2: Industrial applications of Pneumatics

Material Handling	Manufacturing	Other applications
Clamping	Drilling	Aircraft
Shifting	Turning	Cement plants
positioning	Milling	chemical plants
Orienting	Sawing	Coal mines
Feeding	Finishing	Cotton mills
Ejection	Forming	Dairies
Braking	Quality Control	Forge shops
Bonding	Stamping	Machine tools
Locking	Embossing	Door or chute control
Packaging	Filling	Turning and inverting parts
Feeding		
Sorting		
stacking		

1.4 PROPERTIES OF AIR

1.4.1 Composition: Air is one of the three states of matter. It has characteristics similar to those of liquids in that it has no definite shape but conforms to the shape of its container and readily transmits pressure. Gases differ from liquids in that they have no definite volume. That is , regardless of the size or shape of the containing vessel, a gas will completely fill it. Gases are highly compressible, while liquids are only slightly so. Also, gases are lighter than equal number of liquids, making gases less dense than liquids.

Air is a mechanical mixture of gases containing by volume, approximately 78 % of nitrogen and 21 % of oxygen, and about 1 % of other gases, including argon and carbon dioxide. Water being the most important remaining ingredient as far as pneumatics is concerned. The dilution of the oxygen by nitrogen makes air much less chemically active than pure oxygen but it is still capable of causing spontaneous combustion or explosion , particularly if oil vapor at an elevated temperature is present, as may occur in an air receiver.

Air is colorless, odorless, tasteless, and compressible and has weight. Air has a great affinity with water and unless specifically dried, contains considerable quantities of water vapour, sometimes as much as 1% by weight. Life on earth depends on air for survival and man harness its forces to do useful work. [Table 1.3](#) gives the physical properties of air

Table 1.3: Properties of air

Property	Value
Molecular weight	28.96 kg/kmol
Density of air at 15 °C and 1 bar	1.21 kg/m ³
Boiling point at 1 bar	191 to -194
Freezing point at 1 bar	-212 to -216
Gas constant	286.9 J/kg K

1.4.2 Free air and Standard air

In pneumatics, the existence of the following two conditions of atmospheric air is well accepted

- **Free air:** Air at the atmospheric condition at the point where the compressor is located is defined as free air. Free air will vary with atmospheric conditions like altitude, pressure and temperature.
- **Standard air:** It is also called normal air. It is defined as the air at sea level conditions (1.01324 bar as per ISO –R554 and 20 °C and Relative humidity of 36%). The condition of normal atmosphere is used as a basis for getting average values for compressor delivery volumes, efficiencies and operating characteristics.

1.4.3 Atmospheric pressure, Gauge pressure and Absolute pressure

Air has mass and exerts a pressure on the surface of the earth. A barometer consisting of an inverted tube close at the top will support a column of mercury at exactly 760 mm at sea level when measured at standard conditions. Pressure above one atmosphere (~ 1 bar) are positive, whereas the pressure below one atmosphere cause a vacuum to be formed. Both positive pressures and vacuum pressures have useful purposes in pneumatics. Vacuum measurement is usually given a mm of mercury and then converted into the holding force for such devices such as suction pads and cylinders with a specified diameter.

Atmospheric pressure: The earth is surrounded by air. Since air has weight it can exert a pressure on the earth's surface. The weight of the column of air on one square meter of earth's surface is known as atmospheric pressure or reference pressure.

The atmospheric pressure varies slightly from day to day. In pneumatic circuit calculations, standard atmospheric pressure is taken as 101.325 kPa.(14.7 psia)(760 mm of Hg). The atmospheric pressure is measured using barometer.

Atmospheric pressure = Density x Acceleration due to gravity x height of barometer column (usually mercury)

$$p_{atm} = \rho g h,$$

For a mercury we can use ,

$$\rho = 13600 \frac{kg}{m^3}, \quad g = 9.81 \frac{m}{s^2}, \quad h = 760 \text{ mm at sea level}$$

$$p_{atm} = \rho g h = 13600 \times 9.81 \times 0.760 = 101396 \frac{N}{m^2} = 1.013 \text{ atm} = 1.013 \text{ bar}$$

Gauge Pressure: In pneumatic application, pressure is measured using pressure gage and pressure gauges are calibrated to indicate the pressure above that of the Atmospheric pressure. Gauge pressure refers to pressure indicated by pressure gauge.

Absolute pressure: refers to the true or total pressure. Absolute pressure = Atmospheric pressure + Gauge pressure. Calculations involving formulae associated with the Gas laws must be made with absolute pressure. **Figure 1.1** shows the difference between the gauge and absolute pressure. Let's examine the two pressure levels P_1 and P_2 .

Relative to a perfect vacuum, they are

$$p_1 = 0.7 \text{ bar (absolute) (a pressure less than a atmospheric pressure)}$$

$$p_2 = 2 \text{ bar (absolute) (a pressure greater than a atmospheric pressure)}$$

Relative to the atmosphere, they are

$$p_1 = -0.3 \text{ bar (Gauge) (Suction) (or vacuum)}$$

$$p_2 = 1 \text{ bar (Gauge)}$$

As can be seen from **Figure 1.1**, the following rule can be used in pressure conversion calculations

Absolute pressure = Gauge pressure + Atmospheric pressure

It should be noted that vacuum or suction pressures exist in certain locations of fluid power systems (for example, in the inlet or suction lines of pumps). Therefore, it is important to understand the meaning of pressures below atmospheric pressure. One way to generate a suction pressure is to remove some of the fluid from a closed vessel initially containing fluid at atmospheric pressure.

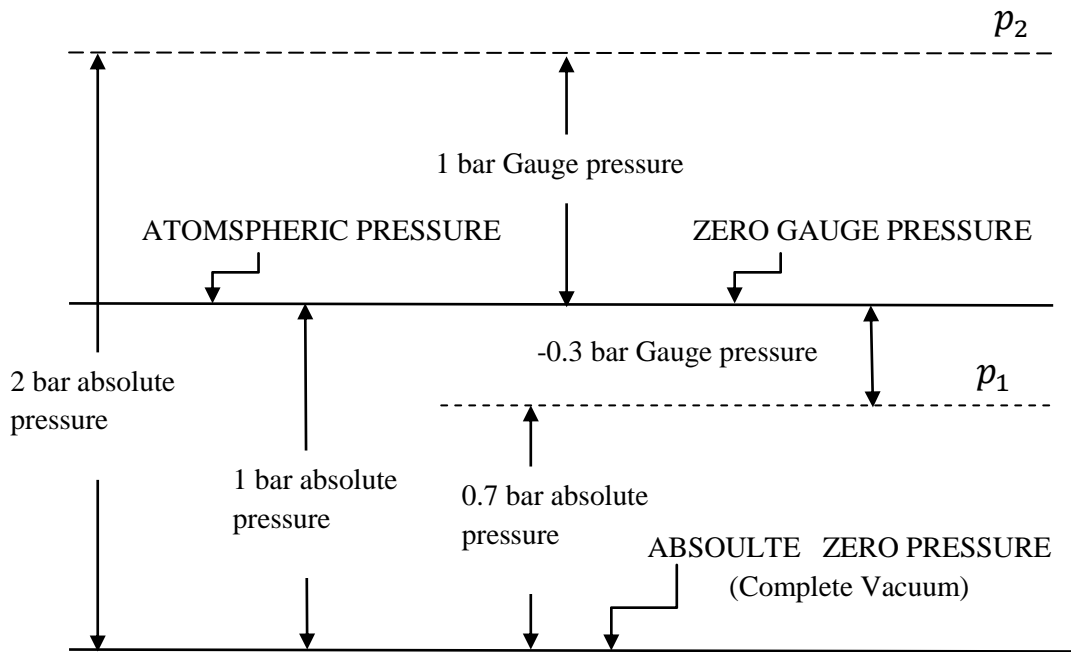

Figure 1.1 Difference between absolute and gauge pressure.

1.4.4 Variation of pressure with altitude

According to Barometric law, the atmospheric pressure decreases exponentially with the increase in altitude. The relation is shown graphically in the **Figure 1.2**. Variation of pressure with respect to altitude is linear up to 6000 m and pressure drops about 11 kPa per 1000 m change in altitude.

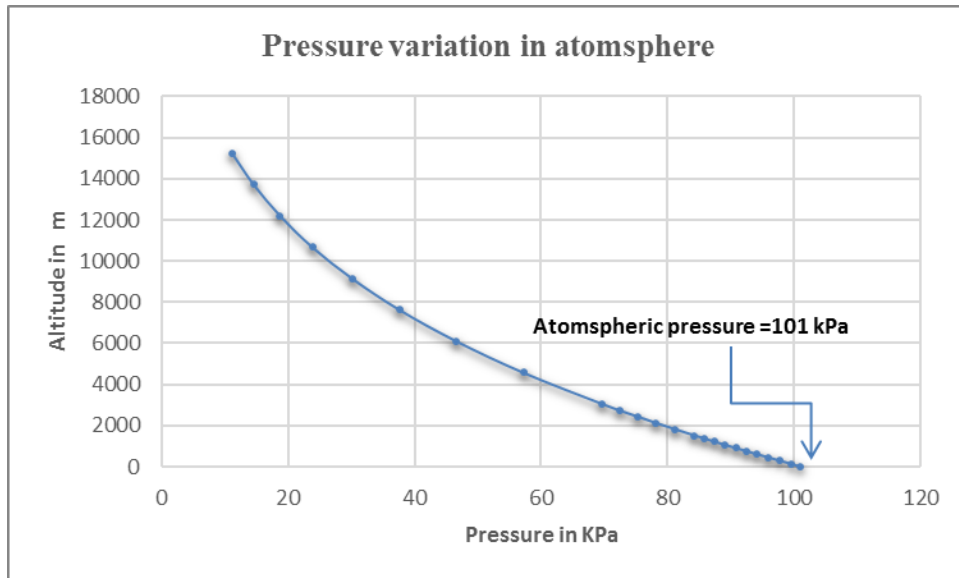

Figure 1.2 Pressure variations in atmosphere.

1.5 GAS LAWS

Early experiments were conducted concerning the behavior of air and similar gases. These experiments were conducted by scientists such as Boyle, Charles and Gay-Lussac. The results of their experiments indicated that gases behaviors follow the law known as ideal gas laws.

1.5.1 Boyle's Law

Robert Boyle (1627-1691), an English scientist, was among the first to experiment with the pressure volume relationship of gas at constant temperature.

Statement: If a given mass of a gas is compressed or expanded at a constant temperature, then the absolute pressure is inversely proportional to the volume.

$$\text{Pressure} \propto \frac{1}{\text{Volume}}, \quad \text{when temperature} = \text{constant}$$

$$\text{or } pV = \text{constant, for state 1 and 2, } p_1V_1 = p_2V_2$$

Example 1.1: .50 mm diameter piston of the pneumatic cylinder of [Figure 1.3](#) retracts 130 mm from its present position. ($p_1 = 2\text{bar (gauge)}$) $V_1 = 300\text{cm}^3$) due to the external load on the rod. If the part at the blind end of the cylinder is blocked, find the new pressure, assuming temperature remains constant.

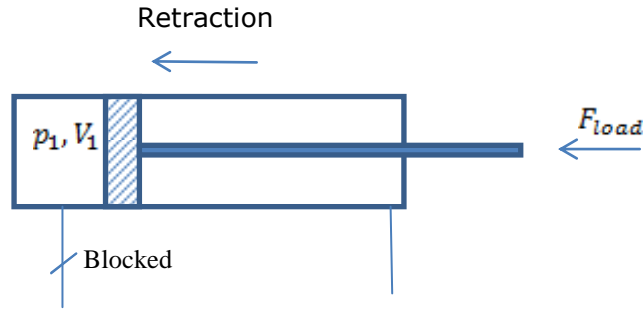

Figure 1.3

Given Data:

$D = \text{diameter of piston} = 50\text{mm} = 5\text{cm}$

$\text{Stroke} = L = 130\text{ mm} = 13\text{ cm}$

$$p_1 = 2\text{bar (gauge)} \quad V_1 = 300\text{cm}^3$$

Solution

$$p_1 = 2\text{bar (gauge)} + \text{atmospheric pressure} = 3\text{ bar abs.}$$

$$\text{Final volume} = V_2 = V_1 - \left(\frac{\pi}{4} D^2 L\right) = 300 - (0.7854 \times (5^2) \times 13) = 45\text{cm}^3$$

Since the temperature is constant, we can use Boyle's Law

$$p_1 V_1 = p_2 V_2$$

$$3 \times 300 = p_2 \times 45$$

Thus, $p_2 = 20\text{ bar (abs)} = \mathbf{19\text{ bar (gauge)}}$

Example 1.2: . Four cubic m of nitrogen are under a pressure of 7 bar (gauge) the nitrogen is allowed to expand to a volume of 6 cubic m . What is the new gauge pressure ?

Given Data:

$$p_1 = 7\text{bar (gauge)} = 8\text{ abs}, \quad V_1 = 4\text{ m}^3$$

$$V_2 = 6\text{ m}^3$$

Solution

Since the temperature is constant, we can use Boyle's Law

$$p_1 V_1 = p_2 V_2$$

$$8 \times 4 = p_2 \times 6$$

Thus, $p_2 = 5.333 \text{ bar (abs)} = 4.333 \text{ bar (gauge)}$

Example 1.3: . Piston compresses air at atmospheric pressure to $1/7^{\text{th}}$ the volume as illustrated in the **Figure 1.4** Assuming constant temperature, what is the gauge pressure of the resulting air?

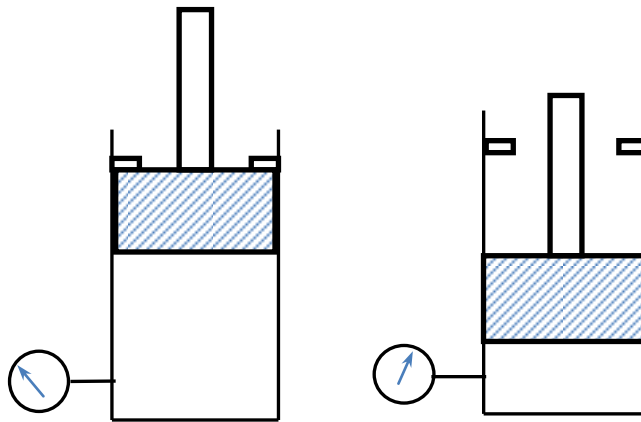

Figure 1.4

Solution

$$\frac{V_2}{V_1} = \frac{1}{7} \text{ or } \frac{V_1}{V_2} = 7$$

Since the temperature is constant, we **can use** Boyle's Law

$$p_1 V_1 = p_2 V_2$$

$$p_2 = p_1 \times \frac{V_1}{V_2}$$

$$p_2 = 1 \times \frac{7}{1} = 7 \text{ bar (absolute)}$$

$$p_2 = 6 \text{ bar (gauge)}$$

1.5.2. Charles law

Boyle's law assumes conditions of constant temperature. In actual situations this is rarely the case. Temperature changes continually and affects the volume of a given mass of gas.

Jacques Charles (1746 to 1823), a French physicist, provided much of the foundations for modern kinetic theory of gases. Through experiments, he found that all gases expand and contract proportionally to the change in the absolute temperature, providing the pressure remains constant.

Statement: If a given mass of a gas is heated or cooled at a constant pressure, then the volume is directly proportional to the absolute temperature.

Volume \propto *Temperature*, when pressure = constant

$$\text{or } \frac{V}{T} = \text{constant, for state 1 and 2, } \quad \frac{V_1}{T_1} = \frac{V_2}{T_2}$$

Example 1. 4: The cylinder of Figure 1.4 as an initial position where $p_1 = 2 \text{ bar (gauge)}$ ($V_1 = 300 \text{ cm}^3$) as controlled by the load on the rod. The air temperature is 30°C . The load on the rod is held constant to maintain constant air pressure, but the air temperature has increased to 65°C . Find the new volume of air the blank end of the cylinder.

Given Data:

$$p_1 = 2 \text{ bar (gauge)} \quad V_1 = 300 \text{ cm}^3$$

Solution

Since the pressure is constant, From Charles law, we have

$$\frac{V_1}{T_1} = \frac{V_2}{T_2}$$

$$T_1 = \text{temperature in Kelvin} = 30 + 273 = 303 \text{ K}, \quad T_2 = 65 + 273 = 338 \text{ K}$$

$$\frac{300}{303} = \frac{V_2}{338}$$

$$\text{Solving we get, } V_2 = 145 \text{ cm}^3 = 145 \times 10^{-6} \text{ m}^3$$

Example 1.5: A sample of $H_2(g)$ occupies a volume of 69.37 cm^3 at a pressure of exactly 1 atm when immersed in a mixture of ice and water. When the gas (at the same pressure) is immersed in boiling benzene, its volume expands to 89.71 cm^3 . What is the boiling point of benzene?

Given Data:

$$p_1 = 1 \text{ bar (gauge)} \quad V_1 = 69.37 \text{ cm}^3 \quad V_2 = 89.71 \text{ cm}^3,$$

Solution

Since the pressure is constant, From Charles law, we have

$$\frac{V_1}{T_1} = \frac{V_2}{T_2}$$

$$T_1 = \text{temperature in Kelvin} = 0 + 273 = 273 \text{ K},$$

$$\frac{69.37}{273} = \frac{89.71}{T_2}$$

Solving we get, $T_2 = 353.05 \text{ K}$, yields the desired result. (The ice-water mixture must be at 273.15 K , the freezing point of water.)

Example 1.6: A cylinder of gas under a pressure of 125 bar at 70°F is left out in the sun in tropics and heats up to a temperature of 130°F . What is the new pressure within the cylinder.

Given Data:

$$p_1 = 125 \text{ bar (gauge)} \quad T_1 = 70^\circ\text{F} = 70 + 460 = 530 \text{ K},$$

$$T_2 = 130^\circ\text{F} = 130 + 460 = 590 \text{ K}$$

Solution

Since the pressure is constant, From Charles law, we have

$$\frac{P_1}{T_1} = \frac{P_2}{T_2}$$

$$\frac{125}{530} = \frac{P_2}{590}$$

Solving we get, $P_2 = 140.3 \text{ bar (absolute)} = 139.3 \text{ bar (gauge)}$

1.5.3 Gay-Lussac's Law

A third gas law may be derived as a corollary to Boyle's and Charles's laws. Suppose we double the thermodynamic temperature of a sample of gas. According to Charles's law, the volume should double. Now, how much pressure would be required at the higher temperature to return the gas to its original volume? According to Boyle's law, we would have to double the pressure to halve the volume. Thus, if the volume of gas is to remain the same, doubling the temperature will require doubling the pressure. This law was first stated by the Frenchman Joseph Gay-Lussac (1778 to 1850).

Statement: At constant pressure, the absolute pressure of an ideal gas will vary directly with the absolute temperature.

Pressure \propto Temperature, when Volume = constant

$$\text{or } \frac{p}{T} = \text{constant, for state 1 and 2, } \quad \frac{p_1}{T_1} = \frac{p_2}{T_2}$$

Example 1.7: The cylinder of Figure (same as above figure no) has a locked position ($V_1 = \text{constant}$). $p_1 = 2\text{bar (gauge)}$ $T_1 = 25^\circ\text{C}$. if temperature increases to 70°C What is the new pressure in the blank end.

Given Data:

$$p_1 = 2\text{bar (gauge)} \quad V_1 = \text{constant}, T_1 = 25^\circ\text{C}, T_2 = 70^\circ\text{C},$$

Solution

Since the volume is constant, by applying Gay –Lussac's law, we get,

$$p_1 = 2\text{bar (gauge)} = 2 + 1 = 3 \text{ bar(absolute)}$$

$$T_1 = \text{temperature in Kelvin} = 25 + 273 = 298 \text{ K}, \quad T_2 = 70 + 273 = 343 \text{ K}$$

$$\frac{p}{T} = \text{constant or } \frac{p_1}{T_1} = \frac{p_2}{T_2}$$

$$\frac{3}{298} = \frac{p_2}{343}$$

Solving we get, $p_2 = 3.45 \text{ bar(absolute)} = 2.45 \text{ bar(gauge)}$

Example 1.8: A compressed air receiver has a volume of 0.5 m^3 is filled with compressed air at 7 bar (gauge) and at a temperature of 40°C . The temperature then cools to 20°C . What is the final pressure?

Given data $V_1 = V_2 = 0.5 \text{ m}^3$, $p_1 = 7 \text{ bar (gauge)} = 7 + 1 = 8 \text{ bar (absolute)}$

$$T_1 = 20^\circ\text{C} = 20 + 273 = 293 \text{ K}$$

$$T_2 = 40^\circ\text{C} = 40 + 273 = 313 \text{ K}$$

Since the volume is constant we can apply, Gay-Lussac law

$$\frac{p_1}{T_1} = \frac{p_2}{T_2}$$
$$\frac{8}{298} = \frac{p_2}{313}$$

Solving we get,

$$\text{Thus, } p_2 = 7.5 \text{ bar (abs)} = \mathbf{6.5 \text{ bar (gauge)}}$$

Example 1.9:

A container is designed to hold a pressure of 2.5 atm. The volume of the container is 20.0 cm^3 , and it is filled with air at room temperature (20°C) and normal atmospheric pressure. Would it be safe to throw the container into a fire where temperatures of 600°C would be reached?

Given data $V_1 = V_2 = 0.5 \text{ m}^3$, $p_1 = 0 \text{ bar (gauge)} = 0 + 1 = 1 \text{ bar (absolute)}$

$$T_1 = 20^\circ\text{C} = 20 + 273 = 293 \text{ K}$$

$$T_2 = 600^\circ\text{C} = 600 + 273 = 873 \text{ K}$$

Since the volume is constant we can apply, Gay-Lussac law

$$\frac{p_1}{T_1} = \frac{p_2}{T_2}$$
$$\frac{1}{293} = \frac{p_2}{873}$$

Solving we get,

$$\text{Thus, } p_2 = 2.98 \text{ bar (abs)} = \sim \mathbf{2 \text{ bar (gauge)}}$$

This concept works in reverse, as well. For instance, if we subject a gas to lower temperatures than their initial state, the external atmosphere can actually force the container to shrink

1.5.4. General gas equation

For any given mass of gas undergoing changes of pressure, temperature and volume, the general gas equation can be used. By combining Boyle's law and Gay-Lussac's law we get,

$$\frac{p_1 V_1}{T_1} = \frac{p_2 V_2}{T_2}$$

Example 1.10: Gas at 80 bar (gauge) and 50 °C is contained in the 1290 cm³ cylinder of **Figure 1.5**. A piston compresses the volume to 1000cm³ while the gas is heated to 120°C. what is the final pressure of the cylinder.

Given Data:

$$p_1 = 80 \text{ bar (gauge)} \quad V_1 = 1290 \text{ cm}^3, \quad V_2 = 1000 \text{ cm}^3 \quad T_1 = 50^\circ\text{C}, T_2 = 120^\circ\text{C},$$

Solution

Since the volume is constant

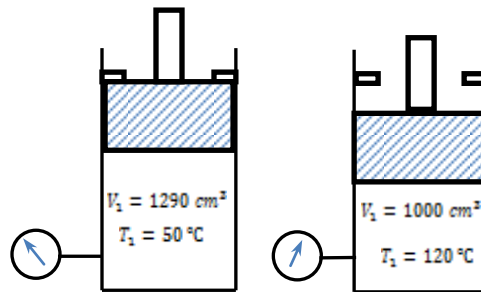

Figure 1.5

$$p_1 = 80 \text{ bar (gauge)} = 81 \text{ bar (absolute)}$$

$$T_1 = 50^\circ\text{C} = 50 + 273 = 323 \text{ K}$$

$$T_2 = 120^\circ\text{C} = 120 + 273 = 393 \text{ K}$$

$$V_1 = 1290 \text{ cm}^3, \quad V_2 = 1000 \text{ cm}^3$$

Using General gas law

$$\frac{p_1 V_1}{T_1} = \frac{p_2 V_2}{T_2}$$

$$\frac{81 \times 1290}{323} = \frac{p_2 \times 1000}{393}$$

Solving we get, $p_2 = 127.13 \text{ bar (absolute)} = 126.17 \text{ bar (gauge)}$

Example 1.11: The empirical formula of benzene is CH. When heated to 100°C in a flask whose volume was 247.2 ml, a sample of benzene vaporized and drove all air from the flask. When the benzene was condensed to a liquid, its mass was found to be 0.616 g. The barometric pressure was 742 mmHg. Calculate (a) the molar mass and (b) the molecular formula of benzene

Solution

Molar mass is mass divided by amount of substance. The latter quantity can be obtained from the volume, temperature, and pressure of benzene vapor

Part (a)

$$V = 247.2 \text{ cm}^3 \times \frac{1 \text{ liter}}{10^3 \text{ cm}^3} = 0.2472 \text{ liter}$$

$$T = 273 + 100 = 373 \text{ K}$$

$$P = 742 \text{ mm Hg} \times \frac{1 \text{ atm}}{760 \text{ mm of Hg}} = 0.976 \text{ atm}$$

Using General gas law

$$n = \frac{pV}{RT} = \frac{0.976 \times 0.2472 \text{ liter}}{0.0820 \text{ liter atm mol}^{-1} \text{K}^{-1} \times 373 \text{ K}} = 7.89 \times 10^{-3} \text{ mol}$$

$$\text{Solving we get, } M = \frac{m}{N} = \frac{0.616 \text{ g}}{7.89 \times 10^{-3} \text{ mol}} = 78.1 \text{ g mol}^{-1}$$

Part (b)

The empirical formula CH would imply a molar mass of $(12.0 + 1.008) \text{ g mol}^{-1}$ or 13.02 g mol^{-1} , The experimentally determined molar mass is 6 times larger.

$$n = \frac{78.1 \text{ g mol}^{-1}}{13.02 \text{ g mol}^{-1}} = 6$$

So molecular formula must be C_6H_6

Example 1.12: Two cubic meter of a gas at 5 bar and 300 K are compressed to a volume of 1 cubic m and then heated to a temperature of 420 K. what is the new gauge pressure.

Given Data:

$$p_1 = 5 \text{ bar (gauge)} \quad V_1 = 2 \text{ m}^3, \quad V_2 = 1 \text{ m}^3 \quad T_1 = 300 \text{ K}, T_2 = 420 \text{ K},$$

Solution

Using General gas law

$$\frac{p_1 V_1}{T_1} = \frac{p_2 V_2}{T_2}$$

$$\frac{6 \times 2}{300} = \frac{p_2 \times 1}{420}$$

Solving we get, $p_2 = 16.8 \text{ bar (absolute)} = 15.8 \text{ bar (gauge)}$

1.6 BASIC COMPONENTS OF PNEUMATIC SYSTEMS

Pneumatic system carries power by employing compressed gas generally air as a fluid for transmitting the energy from an energy-generating source to an energy – use point to accomplish useful work. **Figure 1.6** shows the simple circuit of a pneumatic system with basic components.

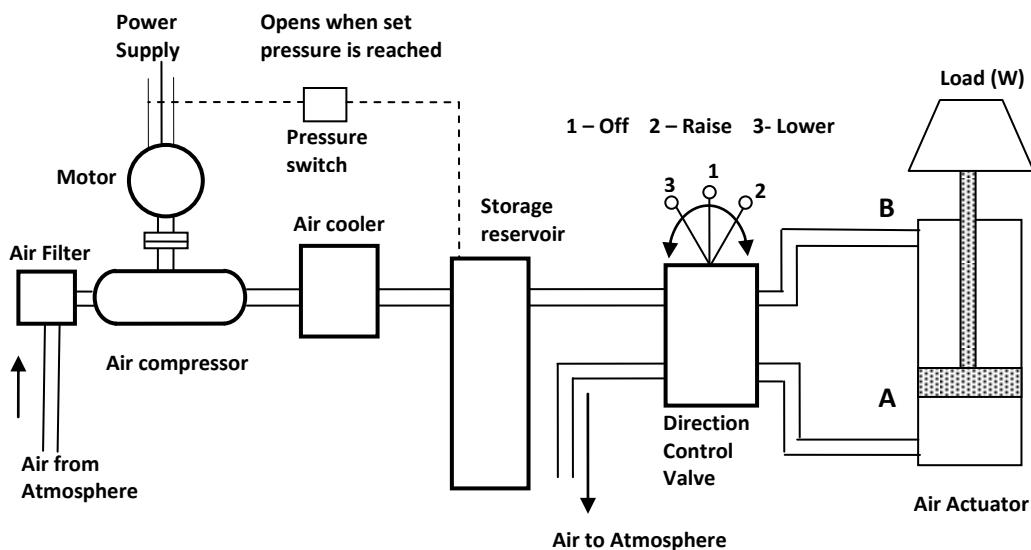

Figure 1.6 Components of Pneumatic System

Functions of components

- Pneumatic actuator converts the fluid power into mechanical power to do useful work
- Compressor is used to compress the fresh air drawn from the atmosphere.
- Storage reservoir is used to store a given volume of compressed air.
- Valves are used to control the direction, flow rate and pressure of compressed air.
- External power supply (Motor) is used to drive the compressor.
- Piping system carries the pressurized air from one location to another.

Air is drawn from the atmosphere through air filter and raised to required pressure by an air compressor. As the pressure rises, the temperature also rises and hence air cooler is provided to cool the air with some preliminary treatment to remove the moisture.

Then the treatment pressurized air needs to get stored to maintain the pressure. With the storage reservoir, a pressure switch is fitted to start and stop the electric motor when pressure falls and reached the required level, respectively.

The cylinder movement is controlled by pneumatic valve. one side of the pneumatic valve is connected to the compressed air and silencers for the exhaust air and the other side of the valve is connected to port A and Port B of the cylinder.

Position of the valve is as follows

1. **Raise:** To lift the weight , the compressed air supply is connected to port A and the port B is connected to the exhaust line, by moving the valve position to the “ Raise”
2. **Lower:** To bring the weight down, the compressed air line is connected to port B and port A is connected to exhaust air line , by moving the valve position to the “lower”
3. **Off:** The weight can be stopped at a particular position by moving the valve to position to “Off” position. This disconnects the port A and port B from the pressurized line and the retrieval line, which locks the air in the cylinder.

Advantages of Pneumatic system

- Low inertia effect of pneumatic components due to low density of air.
- Pneumatic Systems are light in weight.
- Operating elements are cheaper and easy to operate
- Power losses are less due to low viscosity of air
- High output to weight ratio

- Pneumatic systems offers a safe power source in explosive environment
- Leakage is less and does not influence the systems. Moreover, leakage is not harmful

Disadvantages of Pneumatic systems

- Suitable only for low pressure and hence low force applications
- Compressed air actuators are economical up to 50 kN only.
- Generation of the compressed air is expensive compared to electricity
- Exhaust air noise is unpleasant and silence has to be used.
- Rigidity of the system is poor
- Weight to pressure ratio is large
- Less precise. It is not possible to achieve uniform speed due to compressibility of air
- Pneumatic systems is vulnerable to dirt and contamination

1.7 COMPARISON BETWEEN HYDRAULIC AND PNEUMATIC SYSTEM.

Usually hydraulic and pneumatic systems and equipment do not compete. They are so dissimilar that there are few problems of selection between them which cannot be readily be resolved, all factors considered, with a clear preponderance in favour of one or the other. But what of the case where one of the two resources of power is not at hand , and compressed air is used to do something for which oil might be better adopted, and vice versa. Certainly, availability is one of the important factors of selection by this may be outweighed by other factors. In numerous instances, for example, air is preferred to meet certain unalterable conditions. That is, hot spots where there is an open furnace or other potential ignition hazard or in operations where motion is required at extremely high speeds. It is often found more efficient to use a combined circuit in which oil is used in one part and air in another on same machine or process. Comparison between hydraulics and pneumatics is given in **Table 1.4**

Table 1.4 Comparison between Hydraulic and Pneumatic systems

Sl. No	Hydraulic system	Pneumatic system
1	It employs a pressurized liquid as fluid	it employs a compressed gas usually air as a fluid
2	Oil hydraulics system operates at pressures upto 700 bar.	Pneumatics systems usually operate at 5 to 10 bar.
3	Generally designed for closed systems	Pneumatic systems are usually designed as open system
4	System get slow down of leakage occurs	Leakage does not affect the system much more
5	Valve operations are difficult	Easy to operate the valves

6	Heavier in weight	Light in weight
7	Pumps are used to provide pressurized liquids	Compressors are used to provide compressed gas
8	System is unsafe to fire hazards	System is free from fire hazards
9	Automatic lubrication is provided	Special arrangements for lubrication needed.

1.8 COMPARISON OF DIFFERENT POWER SYSTEMS

There are three basic methods of transmitting power electrical, mechanical, and fluid power. Most applications actually use a combination of the three methods to obtain the most efficient overall system. To properly determine which method to use, it is important to know the salient features of each type. For example, fluid systems can transmit power more economically over greater distances than can are mechanical types. However, fluid systems are restricted to shorter distances than are electrical systems.

1.12.1 Electrical Power transmission

Electrical energy in the form of current is transmitted and distributed through wires and cables. The energy medium is controlled using switches, pushbuttons, relays, contactors, timers, sensors, pressure switches etc. Final actuator in this system is electric motor which converts electrical energy into mechanical energy in the form of rotary motion to perform useful work. Electrical systems are suitable for power transmission over long distances. The limitations of electric power include magnetic saturation, which may limit the torque capacity of the motor and material limitation, which may limit the speed and heat dissipation problems. Switching contacts may arc or corrode. Electric arc is a fire hazard in explosive environments. The response time of the electro mechanical solenoid is too slow for today's controllers. The switching time of control elements is usually greater than 10 milliseconds. Electrical systems need to provide for heat dissipation as most systems which generate heat by pressure or friction.

1.12.2 Mechanical Power transmission

Mechanical power is transmitted by employing a variety of kinematic mechanisms such as belts, chains, pulleys, sprockets, gear trains, bar linkages and cams. They are suitable for the transmission of motion and force over relatively short distances. The disadvantages of mechanical power transmission include lubrication problems, limited speed and torque control capabilities, uneven force distribution, and relatively large space requirement

1.12.3 Hydraulic Power transmission

In hydraulic transmission of energy, a pump is used to raise the pressure of oil and energy stored in oil is transmitted through pipes and hoses to perform useful work. They are suitable for power

transmission over intermediate distances; they can be employed over greater distances than mechanical types but not as electrical systems

Hydraulic systems are mechanically stiff, and can be designed to give fast operative and move very heavy loads. They can easily generate linear motion using liner actuators (also called cylinders). Speed control is easy and precise motion of the actuator is possible.

The disadvantages of hydraulic system include fluid leakage, containments and fire hazards with flammable hydraulic fluids.

1.12.4 Pneumatic Power transmission

All gases are readily compressible and it is this property which differentiates them most from liquids as a power transmission medium. In pneumatic transmission of energy, a compressor is used as the power source to raise the pressure of the air to the required level quite slowly. They are suitable for power transmission over intermediate distances. Pneumatic systems use simple equipment has small transmission lines, and do not present a fire hazard.

The disadvantages of pneumatic system include a high fluid compressibility and a small power to size ratio of components. Pneumatic systems are unsuitable for uniform motion. Operating pressure of pneumatics is around 6 to 8 bar. And hence are capable of generating only medium forces. The switching time of control elements is usually greater than 5 milli seconds and the speed of the control signal is 10 to 50 m/s. [Table 1.5](#) give the comparison of all the systems.

Table 1.5 : Comparison of Electrical, mechanical, pneumatic and hydraulic transmission systems

Property	Electrical/Mechanical	Pneumatic	Hydraulic
Energy	IC engines, electrical energy is used to drive motors	Electrical energy is used to drive compressor and other equipments	I C Engines Electric Motor Air Turbine are used to drive hydraulic pumps.
Medium	. There is no medium, Energy is transferred through Levers, Gears, Shafts	Compressed air/gas in Pipes and hoses	Pressurized liquid in Pipes and hoses
Energy storage	Batteries	Reservoir, air tank	Accumulators
Regulations	Variable frequency drives	Pneumatic valves	Hydraulic valves
Transmitters	Transmitted through mechanical components like levers, gears, cams, screw cts	Transmitted through pneumatic cylinders , rotary drives and rotary actuators	Transmitted through hydraulic cylinders, and hydraulic rotary actuators.
Distribution system efficiency	Good	Limited (say up to 1000m)	Good (say up to 100 m)
Operating speed	Low	Limited (up to 1.5 m/s)	Limited (up to 0.5 m/s)

Positioning accuracy	Precision in terms of few micron can be achieved	. Precision in terms of few mm (usually 0.1 mm) can be achieved	Precision in terms of few micron can be achieved
Stability	Good stability is possible using mechanical elements	. Low stability is due to High compressibility of air	Good stability is possible due to low compressibility
Forces	Mechanical elements break down if overloaded. Poor overloading capacity	Protected against overload with system pressure of 6 to 8 bar, forces up to 50 kN can be generated.	Protected against overload with high system pressure of 600 bar, very large forces can be generated.
Cost of energy	Lowest	Highest	Medium
Linear actuators	Short stroke length using mechanical/electrical transmission elements	Is possible using pneumatic actuators (cylinders), it can produce medium force.	Is possible using hydraulic actuators(cylinders), and it can produce heavy force
Rotary actuators	AC , DC, Servo motors and stepper motors can be used	Pneumatic rotary actuators can be used	Hydraulic motors and vane motors can be used
Controllable force	Possible with solenoid and DC motors, Needs cooling and hence complicated	medium force can be controlled easily	High force can be controlled
Work environment	Danger because of electric shock	Noise	Dangerous, unsightly and fire hazardous because of leakage.

Objective Type Questions

1. When the power requirement is ----- like in forging presses, sheet metal press oil hydraulic system is preferred
2. Pneumatic systems have -----output to weight ratio, whereas electrical systems have ----- output to weight ratio
3. Positioning accuracy of pneumatic actuator is ----- compared to hydraulic systems
4. Compressed air actuators are economical up to ----- force only.
5. Low inertia effect of pneumatic components due to ----- density of air.

State True or False

1. Pneumatic systems are used for high pressure and low speed applications
2. Pneumatics is very useful in hazardous environment
3. Compressed air is expensive
4. According to Barometric law, the atmospheric pressure increases exponentially with the increase in altitude
5. If a given mass of a gas is compressed or expanded at a constant temperature, then the absolute pressure is directly proportional to the volume

Review Questions

1. Define Pneumatics
2. List the broad rules followed in the selection of a working medium.
3. List the advantages and disadvantages of compressed air.
4. Why air is used as fluid medium in pneumatic systems
5. List seven reasons for considering pneumatics instead of hydraulic system.
6. Name five characteristics of pneumatic systems
7. List twenty applications of pneumatics
8. Differentiate between Free air and standard air
9. Differentiate between Absolute pressure and atmosphere pressure
10. Discuss various pressure ranges used in pneumatic applications
11. State the following perfect gas laws
 - a) Boyle's Law
 - b) Charles Law
 - c) Gay-Lussac law
 - d) General gas law
12. Name six basic components used in a pneumatic systems.
13. With a simple sketch, explain the functions and working of basic components required for a pneumatic system.
14. List five advantages and five disadvantages of pneumatics
15. Differentiate between hydraulics and pneumatics
16. Compare and contrast between hydraulic, pneumatic and electrical power transmission systems.

Answers

Fill in the Blanks

1. High
2. High/low
3. Low
4. 50 kN
5. Low

State True or False

1. False
2. True
3. True
4. False
5. False